

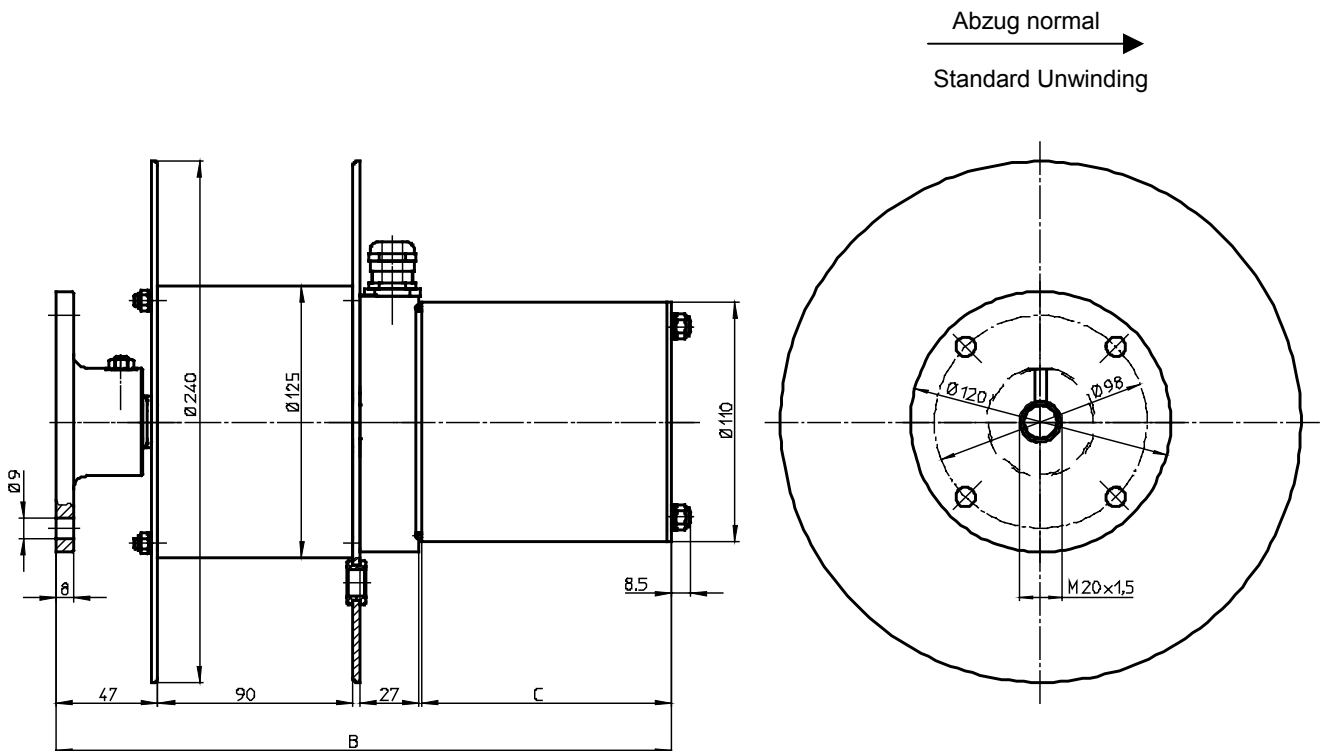

**Federleitungstrommel FKT125
Spring cable reel FKT125**

Maßzeichnung
Dimension sheet
M011-TR-0021D/E

01/04



Ausführung und Abmessung
Types and dimensions

Trommel Cable drum	Schleifring- körper Slipringbody	Strom Current I [A]	Spannung Voltage U [V]	max. Polzahl / c max. number of poles / c			max. Polzahl / B max. number of poles / B		
				3/90	5/115	7/140	3/260	5/285	7/310
FKT125	10 (SN10)	16	415	3/90	5/115	7/140	3/260	5/285	7/310
	15 (SN25)	mA	mV	3/90	5/115	7/140	3/260	5/285	7/310